

The First Interim Storage Program & Safety Review — Points and Evaluations of Safety Review in Japan —

Shuhei KOJIMA

Director, Nuclear Fuel Transport and Storage Regulation Division
Nuclear and Industrial Safety Agency(NISA)

Outline of Application for Interim Storage Facility in Mutsu

Outline

- Name of Company : Recyclable-Fuel Storage Company (RFS)
- Name of Establishment : Recyclable-Fuel Storage Center
- Maximum Storage Capacity : 288 Casks (about 3,000tU)
- Start of Operation : July, 2012 (scheduled)
- Period of Storage : 50 years
- Way of Storage : Dual-Purpose Dry Metal Cask

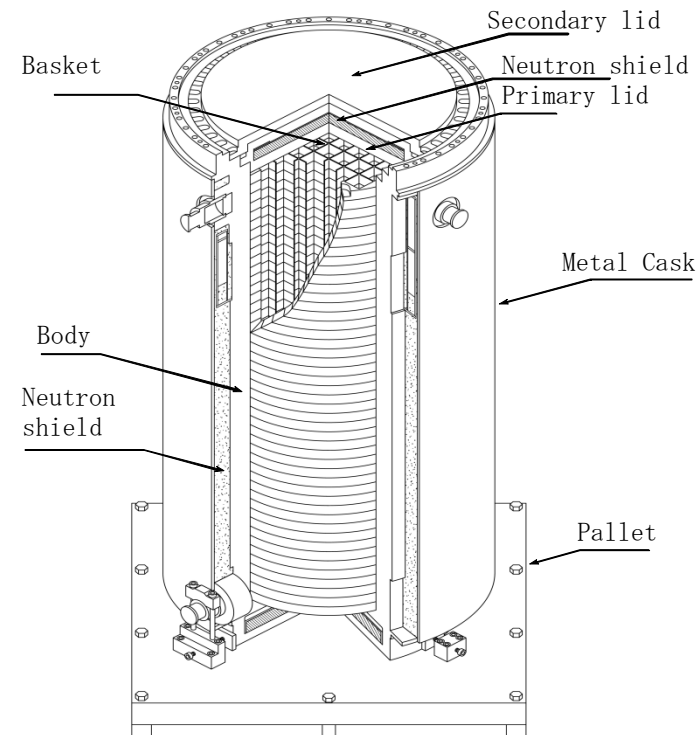
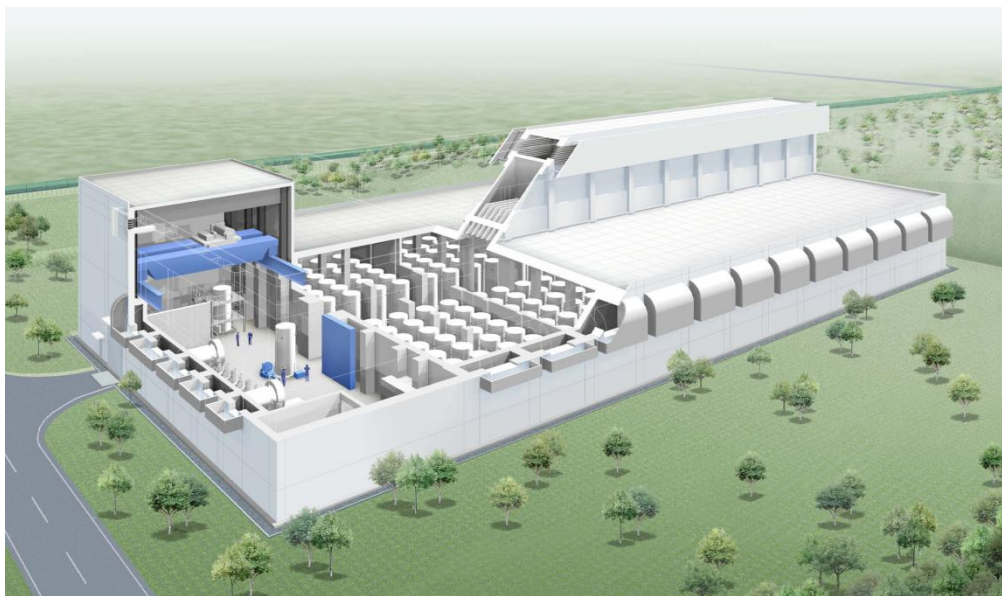

Process of Review

1. The Basic Design / The Basic Design Policy

In a review on business license, a safely review is initially conducted by NISA as an primary review and by the Atomic Energy Commission (AEC) and the Nuclear Safety Commission (NSC) as a second review.

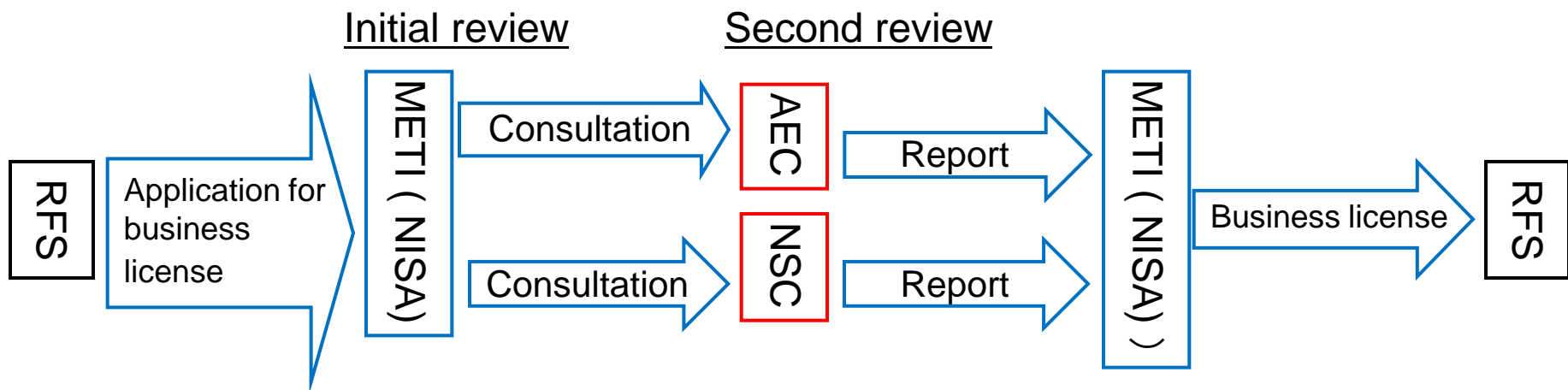

2. Detailed Design

For a license of the design and the method of construction, NISA makes a review if it conforms to the technical criteria.

Review on Business License

The following 4 points are the screening criteria for a review on business license.

1. There is no possibility that a spent fuel storage facility is used except for peaceful purposes.
2. There is no possibility that the planned execution of nuclear development and the utilization is obstructed by the business license.
3. There are enough technical capabilities and accounting foundations to perform business precisely.
4. Location, structure and equipment of facility don't interfere with preventing accidents by spent fuel and contaminated materials by the fuel.

✂The following pages explain a review on ensuring safety

Issues of Safety Review

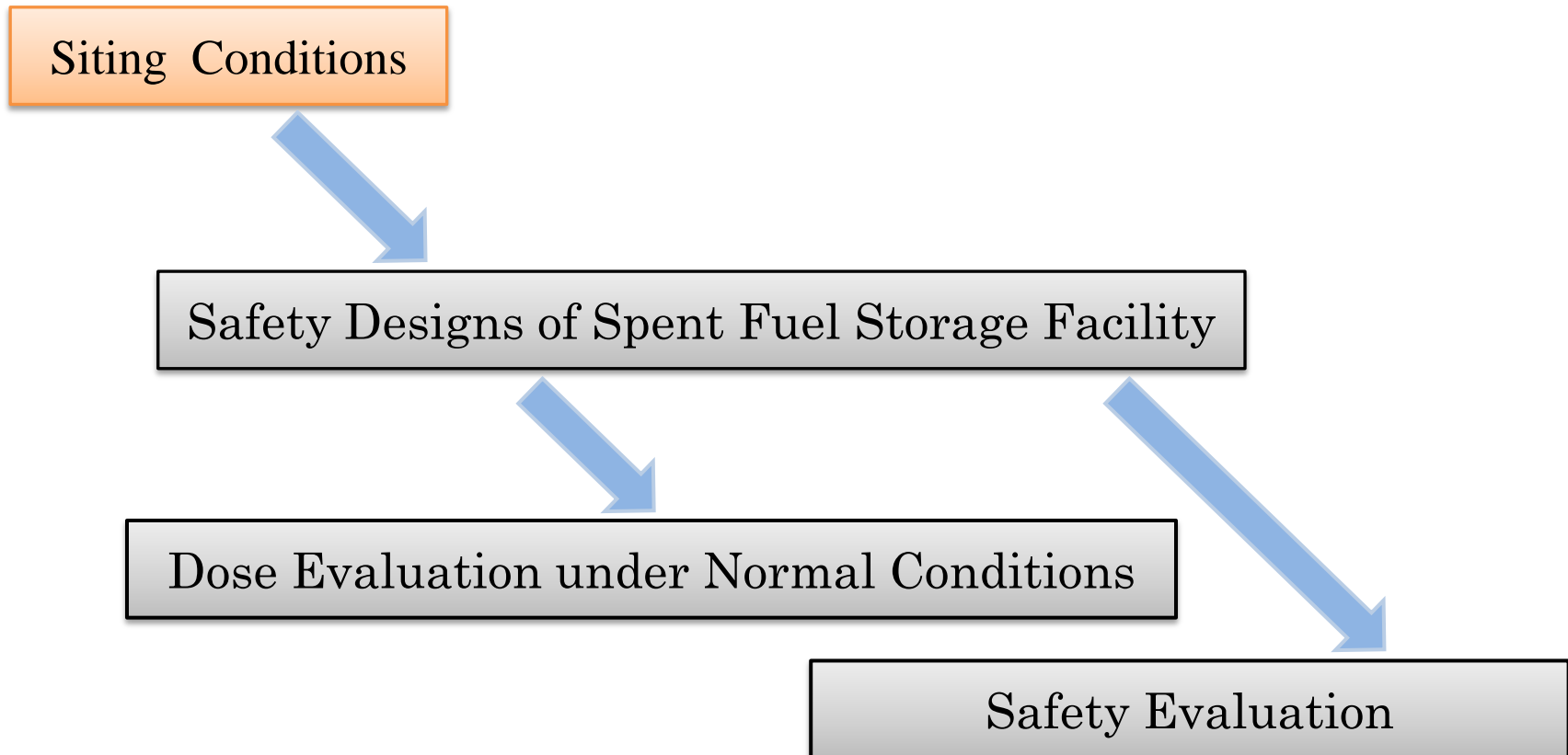

Siting Conditions

1. Site

- Located in the central part of the Shimokita Peninsula along the Tsugaru Straits , north of Mutsu City
- Smooth tableland at 20-30m above sea level. The height of site renovation is 16m above sea level

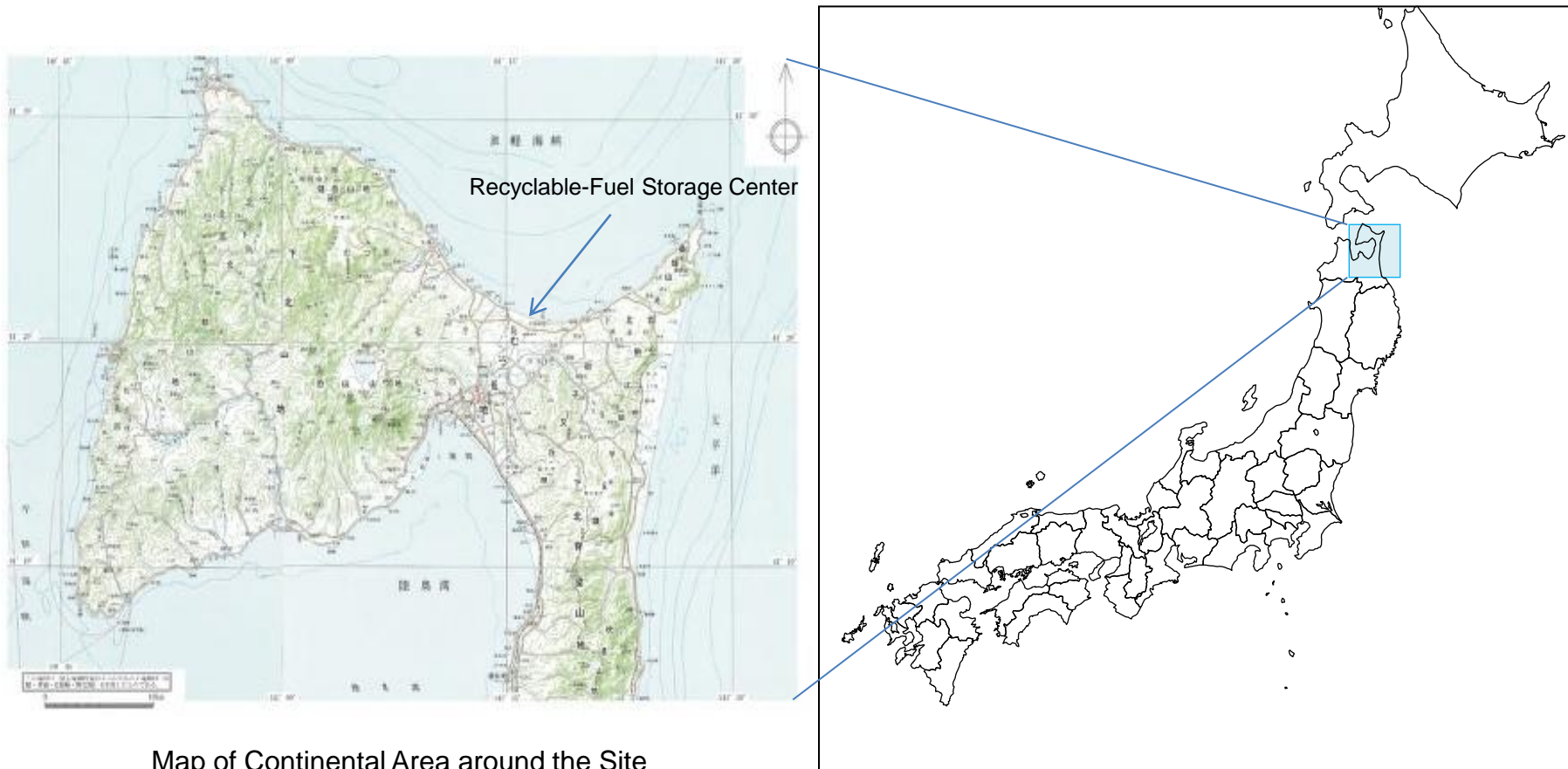

Map of Continental Area around the Site

Siting Conditions

2. Earthquakes

Considerable Active Faults and Basic Earthquake Ground Motion Ss on Seismic Design

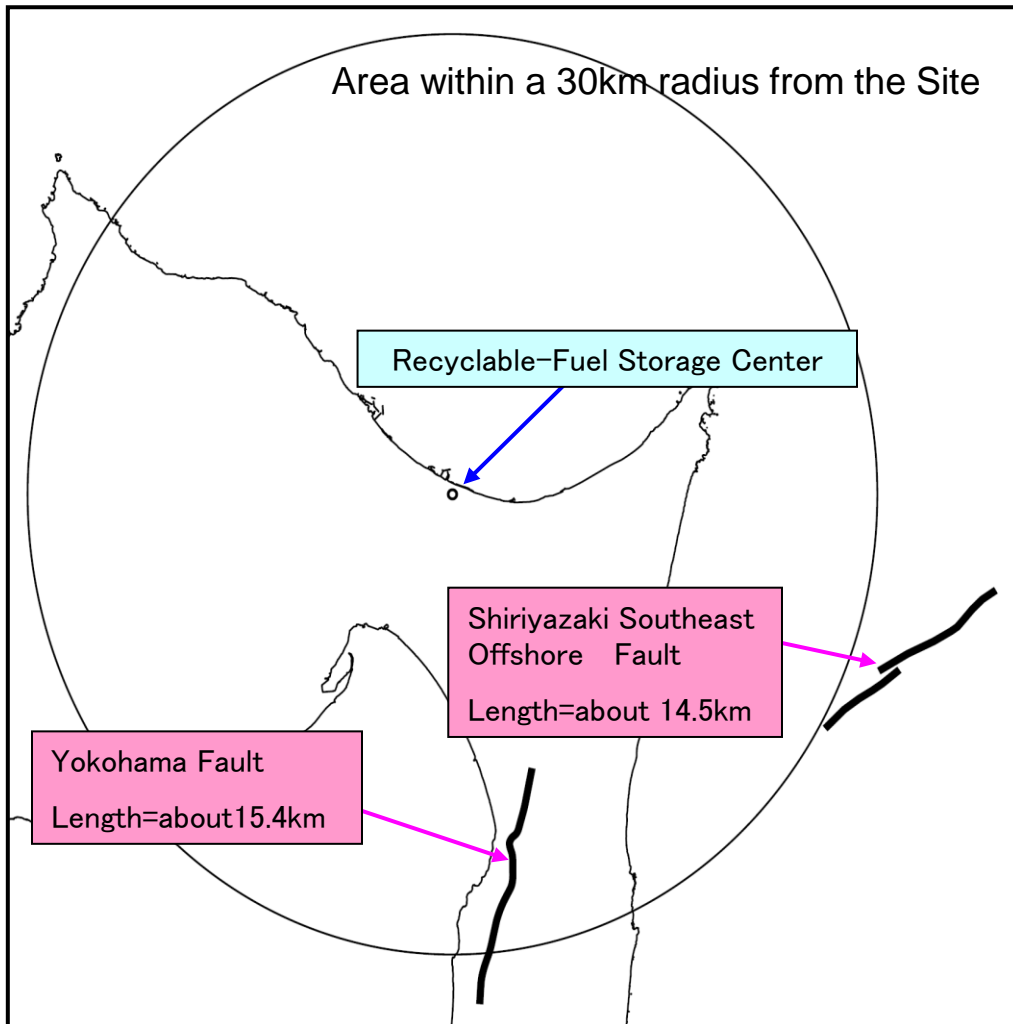

Considerable active faults around the site on seismic design ※

- Yokohama Fault
- Shiriyazaki Southeast Offshore Fault

※Faults that may have been active since the Late Pleistocene (120,000-13,000years ago)



Confirmation of the validity of the considerable basic earthquake ground motion Ss

Siting Conditions

3. Volcanoes

Review on Volcanoes

Needs to confirm the extremely low probability of volcanic disasters effecting on the interim storage site and damaging fundamental safety functions



Comprehensive considerations based on results of document, geomorphic, geological, geophysical and geochemical investigation.

Site Conditions

3. Volcanoes

Evaluation on Volcanoes

Mutsu Hiuchidake Volcano

Osorezan Volcano

Recyclable-Fuel Storage Center



Possibility of Volcanic Activities

【 Osorezan Volcano 】

- End of activities with directly involving magma.
- Evaluated that the current fumarolic activities will continue.
- Extremely low probability that magma will erupt during in-service period of the facility.

【 Mutsu Hiuchidake Volcano 】

- No volcanic activities at present .



Possibility of Impact

Confirmed the validity of evaluation that the possibility of volcanic disaster effecting on the interim storage site and interfering with fundamental safety functions is extremely low during in-service period of the facility.

Siting Conditions

4. Other Points

4.1 Metrological Phenomena

Results of investigations around the site



Reflected on designs of spent fuel storage buildings and metal casks.

4.2 Hydraulic Phenomena

Considerations on floods, extra high tides and tsunamis



Confirmed no probability of serious effects on safety functions of the facility.

4.3 Earthquake Accompanying Phenomena/Events?

Considerations on tsunamis caused by collapse of seabed slopes, etc.

4.4 Social Environment

Investigations on population distribution, settlements, industrial activities and transportations around the site



Confirmed no interference with security.

Issues of Safety Review

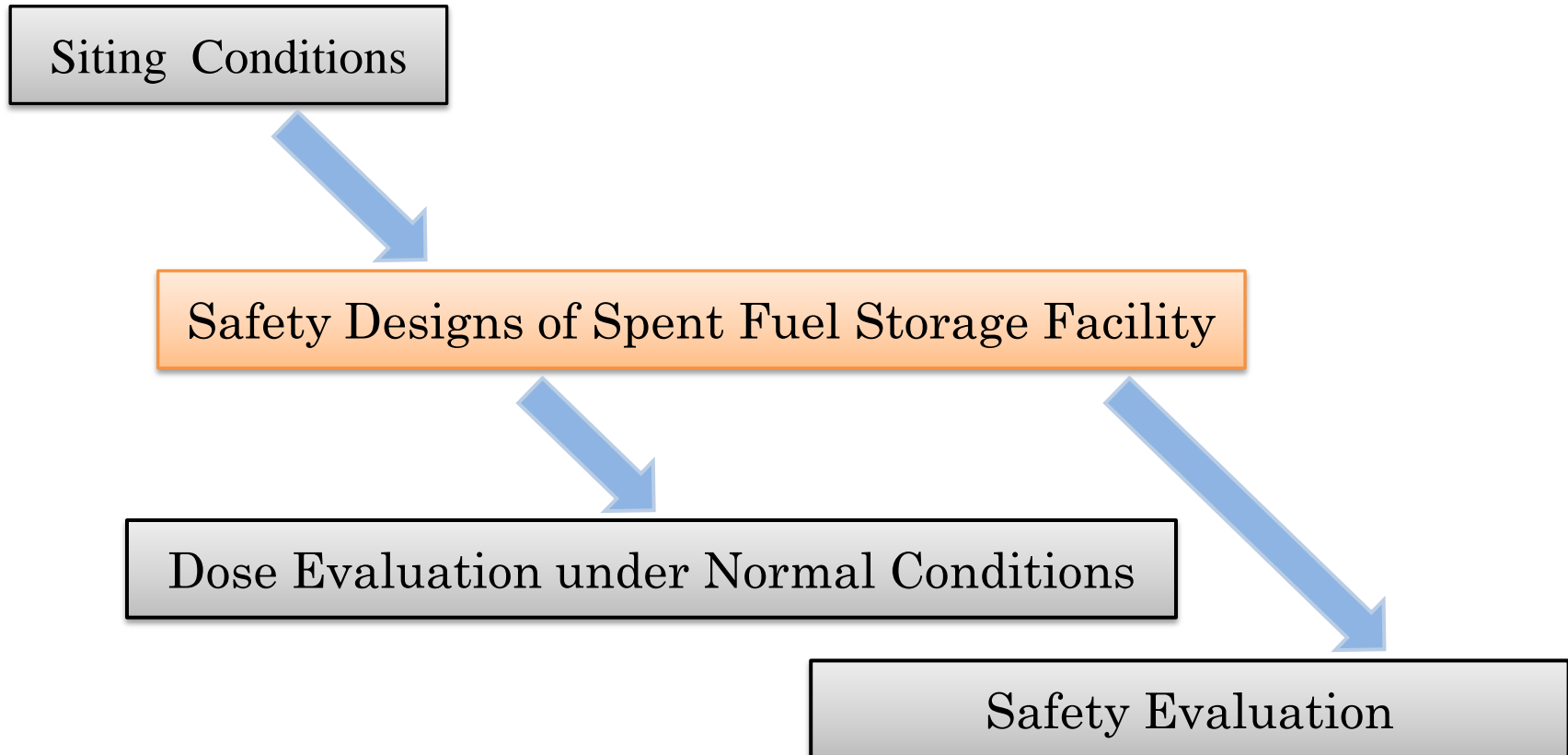

Safety design for Spent Fuel Storage Facility

1. Basic safety functions

Review of the design maintained 4 functions as follows during storage period(50 years)

- 1.1 Confinement
The function of confining spent fuel assembly safely
- 1.2 Shielding
The function of protecting radiation from spent fuel safely
- 1.3 Criticality Prevention
The function of criticality prevention of spent fuel
- 1.4 Heat Removal
The function of decay heat removing from spent fuel safely



Confirmation of the design maintained 4 functions during storage period by evaluation

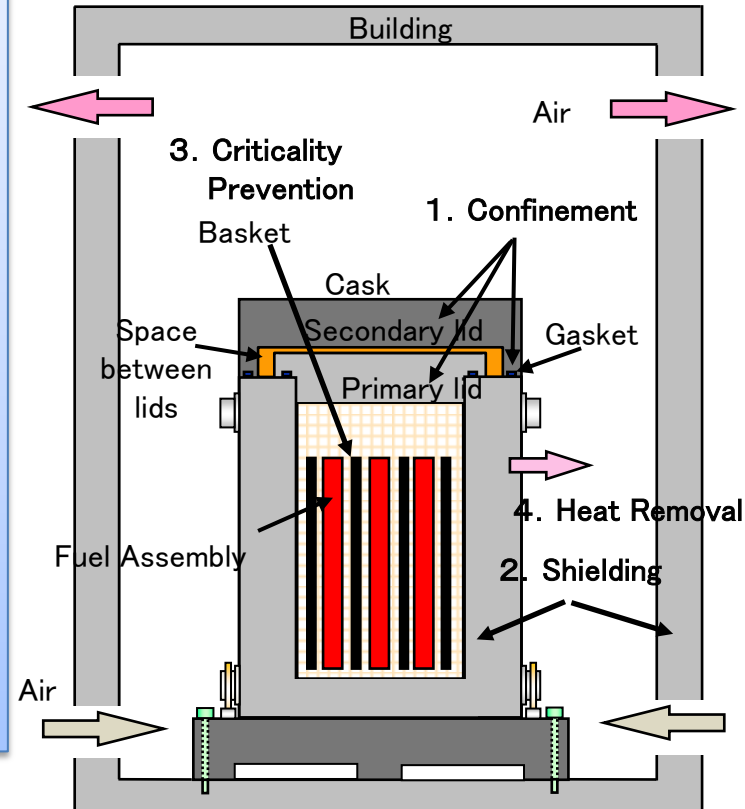

Safety design for Spent Fuel Storage Facility

2. Radiation Control and Environment Safety

- There is no emission of radioactive materials by confinement functions of metal casks and monitoring of the functions.
- There is no radioactive waste generated under normal conditions. Should be generated, it is encapsulated in containers like metal drums and is retained in waste storage room.



Monitoring of dose equivalent in external radiation

Systems for radiation monitoring in and out of the Recyclable-Fuel Storage Center

- » Area Monitoring System (Area Monitor (γ -ray, Neutron))
- » Environment Monitoring system (Monitoring Post, Fluoroglass Dosimeter)

Required areas can be monitored under normal/abnormal conditions and necessary information is shown in monitoring rooms.

Confirmation of the validity of design and policy for radiation control and environment safety

Safety design for Spent Fuel Storage Facility

3. Seismic Designs

Designed to keep fundamental safety functions for the most appropriate designing seismic force

Basic Policy for Seismic Resistant

Basic Earthquake Grand Motion Ss

Expected to give a large effect on facilities with a very slight incidence possibility during in-service period



Significant Facilities for Safety ※

Designed to maintain fundamental safety functions

※ Metal casks, storage buildings, overhead cranes in acceptance areas, carrier wagons



Confirmation of the validity of basic policy for seismic designs

Issues of Safety Review

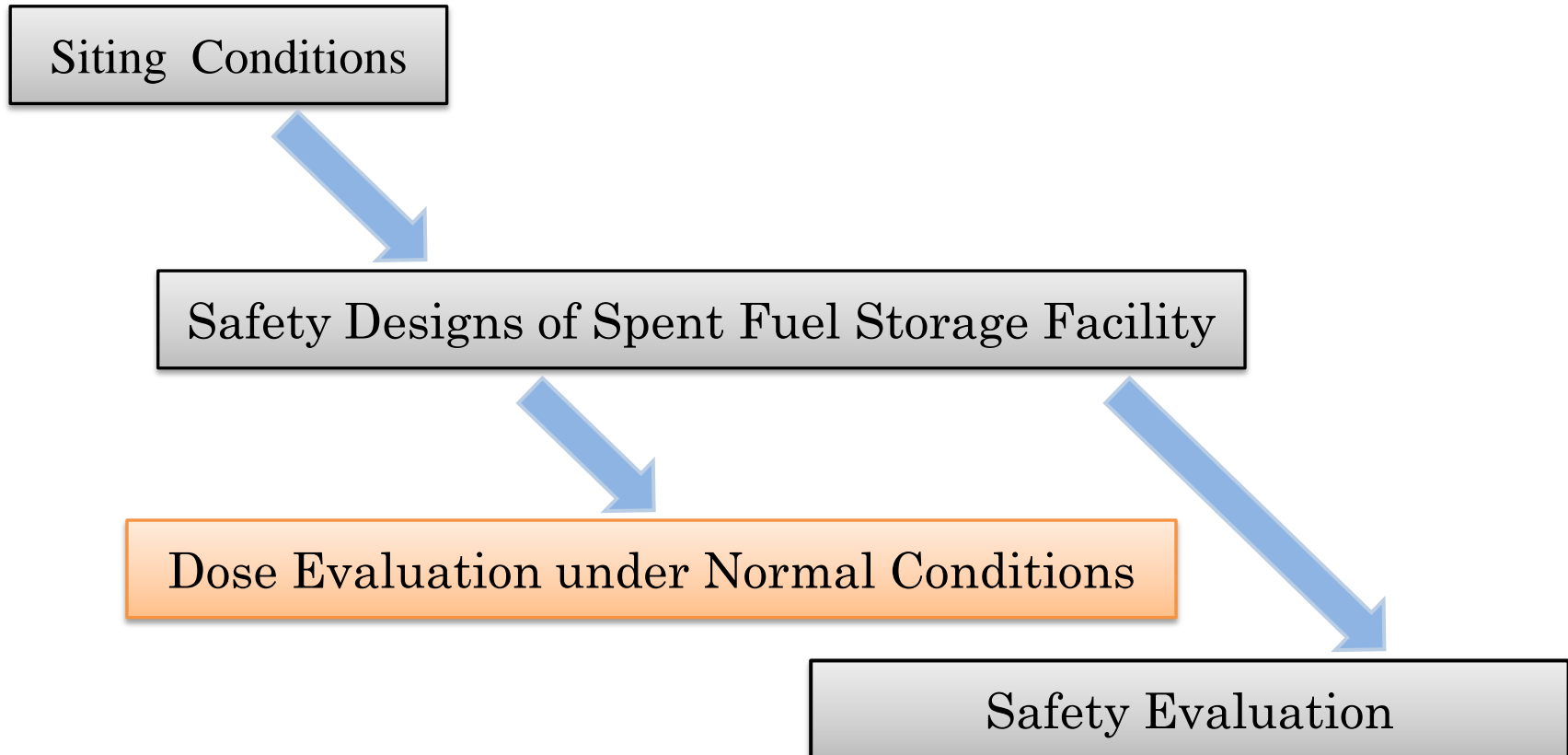

Dose Evaluation under Normal Conditions

Outline of Dose Evaluation

- Confirm the density of radioactive materials on the surface of metal casks is under the statutory surface density limit during removing from nuclear plants and bringing in spent fuel storage facilities
- Store spent fuel assemblies without refilling in other containers
- Monitor the pressure between lids of metal casks during storage period



Public dose under normal conditions is 2.8×10^{-2} mSv of direct and skyshine radiation a year



Confirmation that the public effective dose under normal conditions is 2.8×10^{-2} mSv a year, well below the dose limit (1 mSv/y)

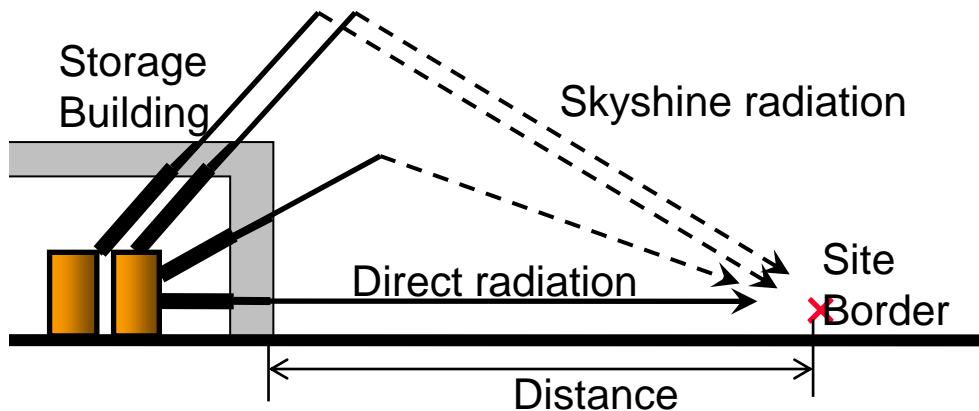

Issues of Safety Review

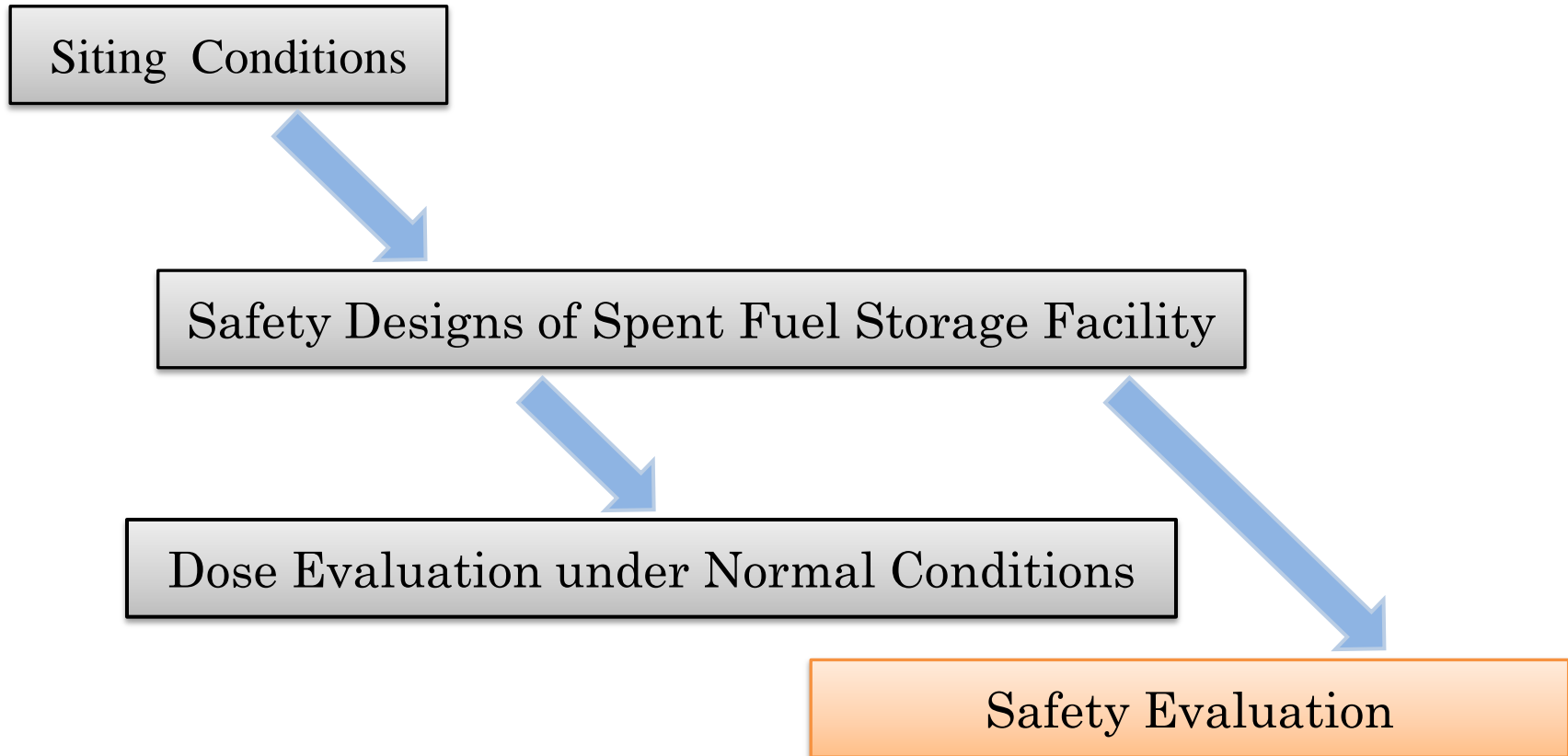

Safety Evaluation

Selection of Possible Events (Initiating Events) to Effect on Fundamental Safety Functions of Metal Casks

Initiating Events

- | | |
|---|---|
| <ol style="list-style-type: none"> 1. False installation of spent fuel 2. Insufficient dryness inside casks 3. False filling of inactive gas in casks 4. Installation failure of cask lids 5. Drop and rollover of casks | <ol style="list-style-type: none"> 6. Crash of casks 7. Heavy object drop on casks 8. Block of air-inlet of storage buildings 9. Fire and Explosion 10. Ageing 11. Other natural disaster |
|---|---|



Selection and evaluation of possible events to have a risk of radiation exposure on general public in cases of occurrence of initiating events

Possible events to have a risk of radiation exposure

No risk of radiation exposure ··· 1·2·5·7·9

Risk of radiation exposure ··· 10



Safety Evaluation



Selection of Significant Accidents from the Viewpoint of Radiation Exposure on General Public

Selected accident events

10. Aged deterioration: Shielding functions of metal casks are decreased when neutron shielding materials flow out from cracks caused by some reason during storage period



Confirmation of no risk of excessive radiation exposure on general public on the assumption of occurrences of maximum credible accident (effective dose for general public: 5.6×10^{-2} mSv)

Issues of Safety Review

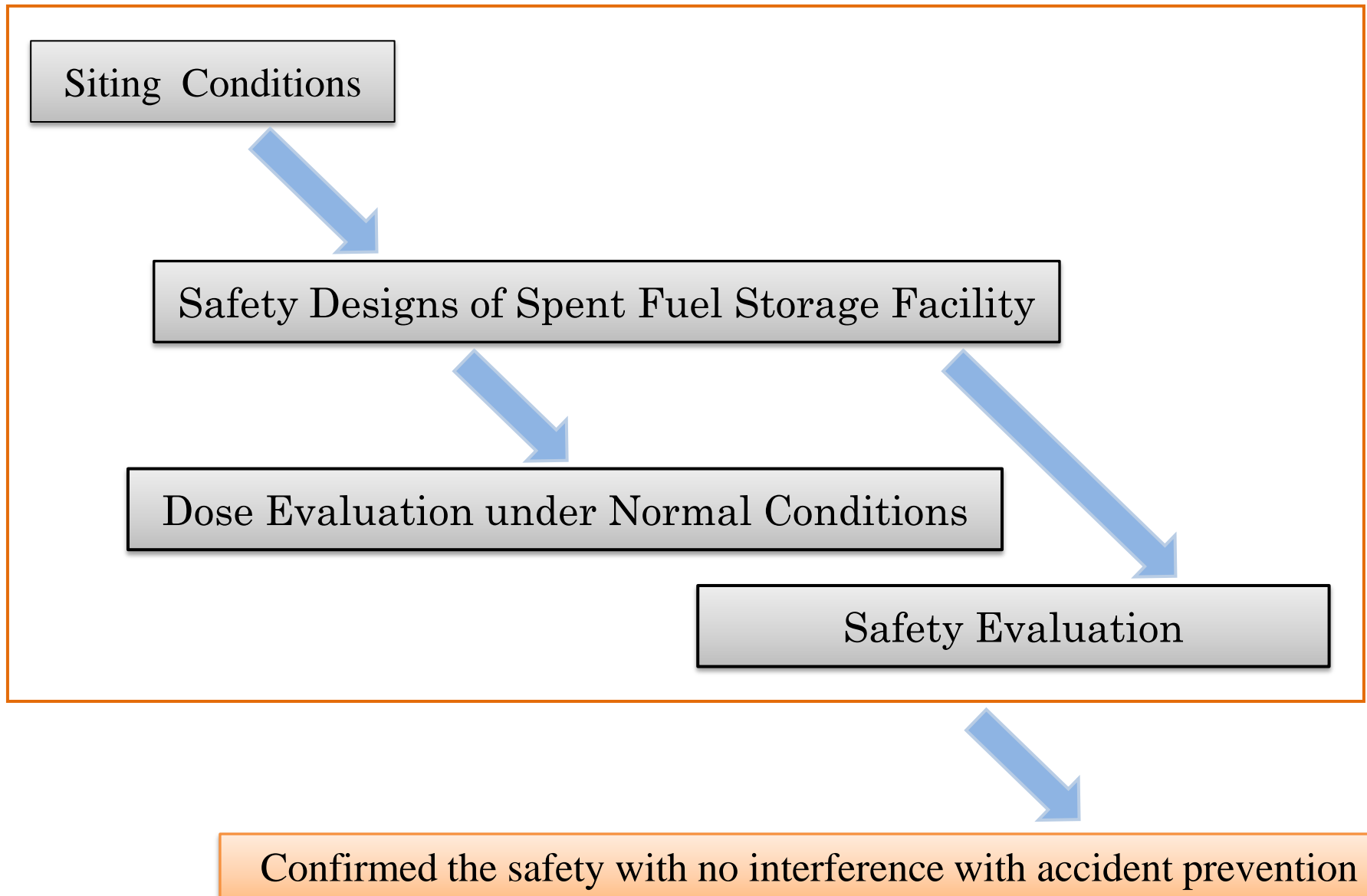

Review on Designs and Construction Methods

In the review on a license for designs and construction methods, the evaluation criteria have 15 items as follows:

- 1. Criticality prevention of spent fuel**
2. Damage prevention from fire
3. Seismic resistant
4. Material and structure
- 5. Heat removal**
- 6. Confinement function**
- 7. Shielding**
8. Ventilation
9. Pollution prevention from contaminated materials by spent fuel
10. Significant facility for safety
11. Transfer and acceptance system
12. Measurement control facility
13. Waste facility
14. Radiation control facility
15. Emergency power system

Safety design for Spent Fuel Storage Facility

1. Criticality prevention of spent fuel

- Criticality prevention by geometric arrangements of baskets and neutron-absorbing materials
- Evaluation with the system infinitely arranging metal casks

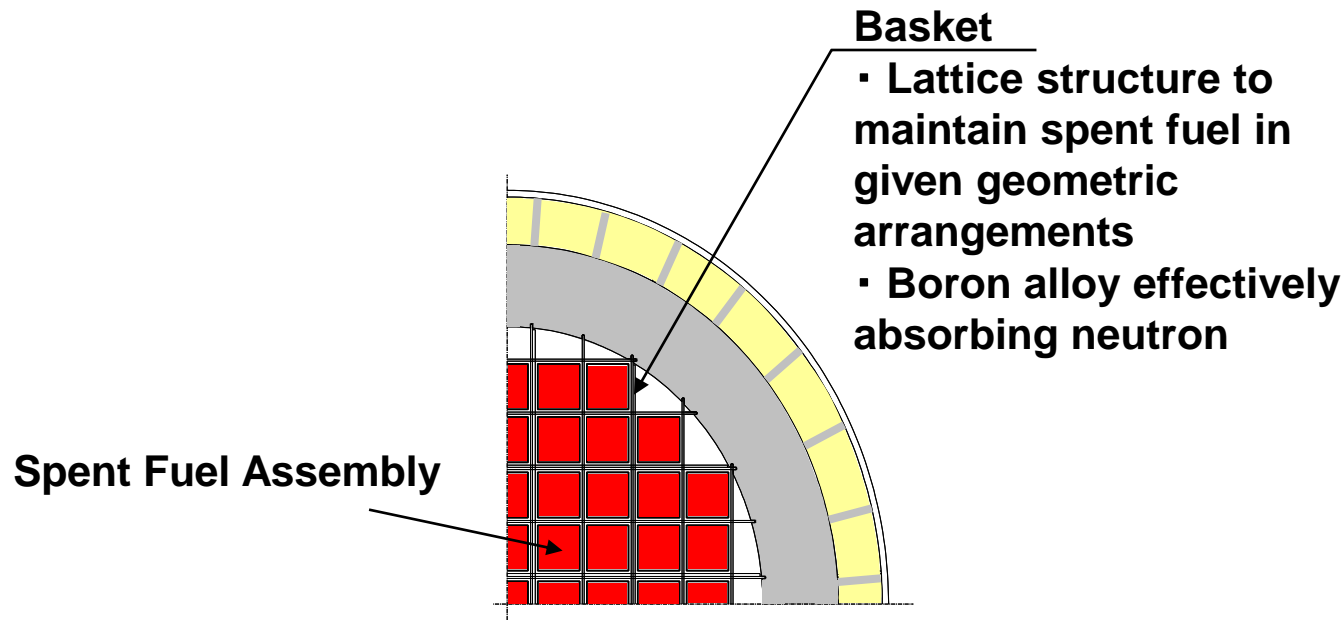

Confirmation of the validity of criticality prevention designs with the effective multiplication constant below 0.95 as the criteria

Safety design for Spent Fuel Storage Facility

5. Heat Removal

5-1. Heat Removal design for Metal Cask

Deliver decay heat of spent fuel to outer surface of metal casks by conduction, convection and radiation, and transfer to the surrounding air, then remove.

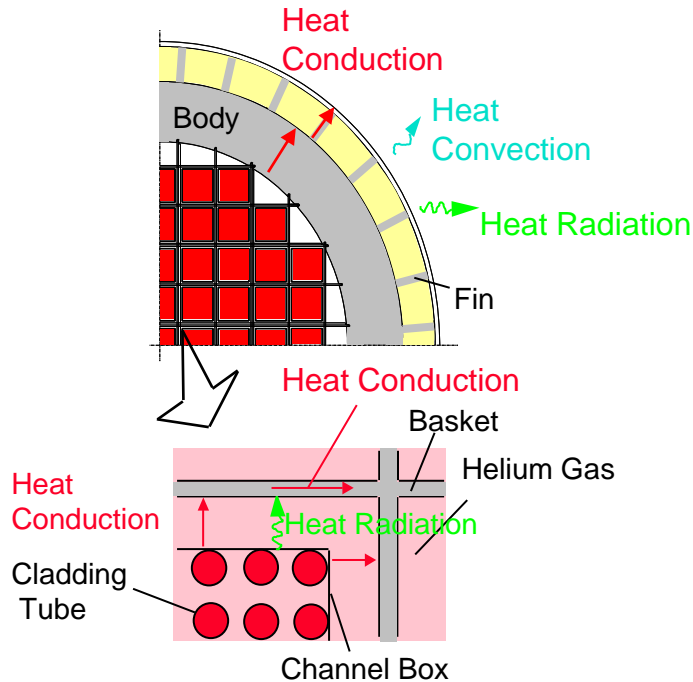

Confirmation of the validity of heat removal designs that fuel cladding tubes are below the limited temperature and structural members are below the temperature of not effecting on its soundness

5-2. Heat Removal design for Storage facility

Diffuse the decay heat of spent fuel delivered from metal cask surface to the surrounding air outside storage buildings by draft power of the air generated in response to its heat quantity.

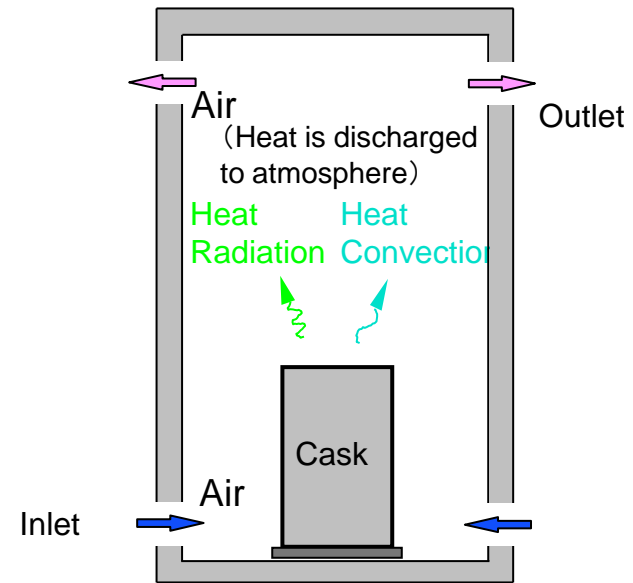

Confirmation of the validity of heat removal designs that the air temperature around metal casks is below 45°C and the concrete temperature is below 65°C

Safety design for Spent Fuel Storage Facility

6. Confinement function

Metal casks block the space including spent fuel assemblies from outside by the bodies and the lids, and maintain negative pressure during designed storage period.

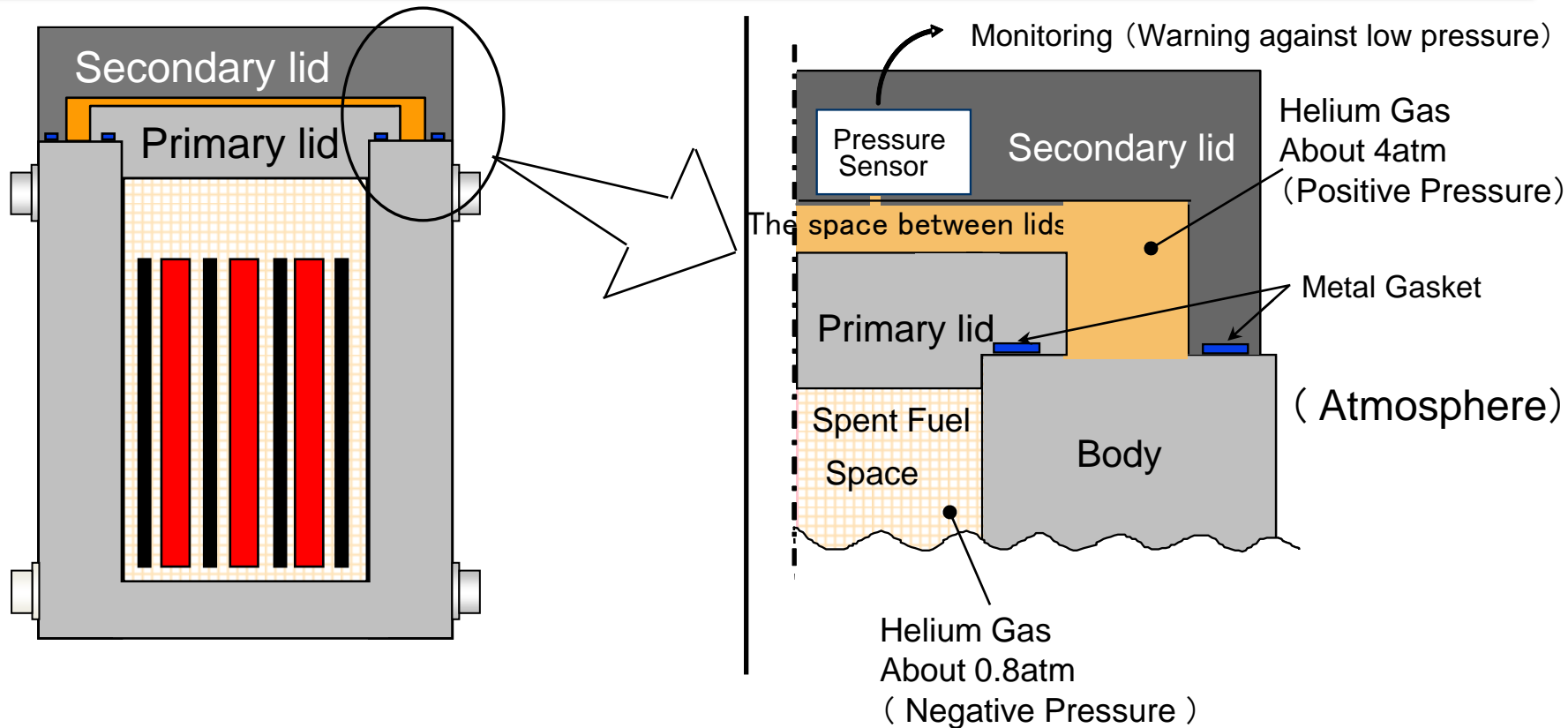

Confirmation of the validity of confinement designs of metal casks

Safety design for Spent Fuel Storage Facility

7. Shielding

Metal casks block radiation from spent fuel assemblies by the bodies and the lids.

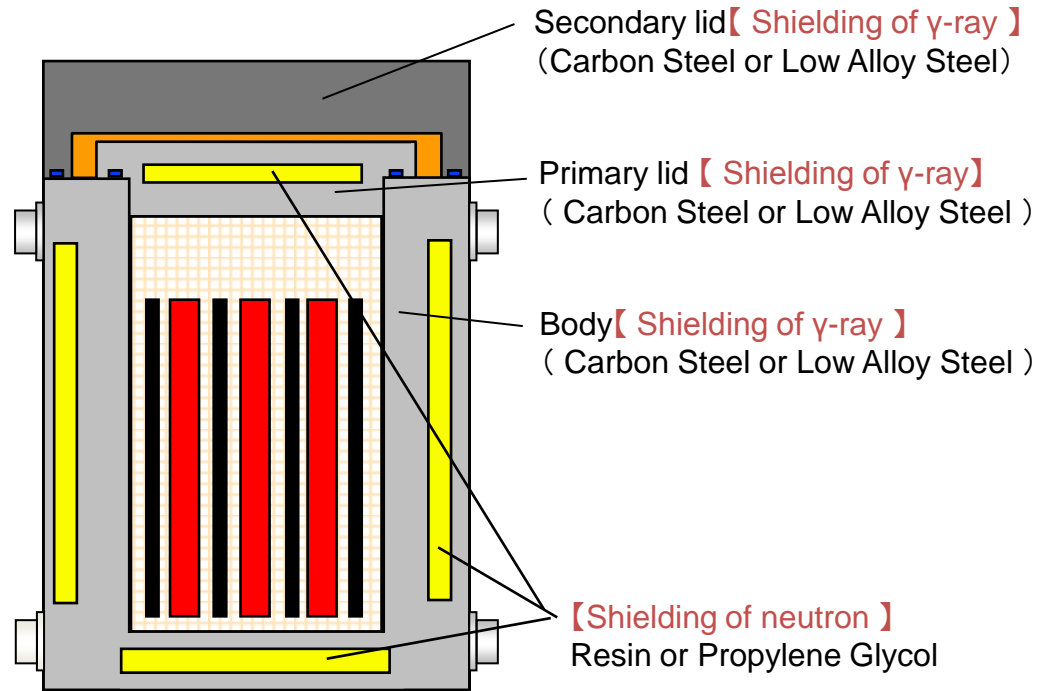

Confirmation of the validity of shielding designs that the dose equivalent rate at the surface and at 1m apart from metal cask surface is below 2mSv/h and 100 μ Sv/h, respectively imposed by the transportation law

Safety analysis on DPDMCs Storage Facilities

▶ Traditional Approach

- From Storage perspective;
 - Chemical deterioration.
 - Thermal deterioration.
 - Mechanical deterioration.
 - Radiation deterioration.
- From Transport perspective;
 - Transport regulations based on TS-R-1.
 - Transport licenses for DPDMCs are generally issued with up to 5 years duration.

Safety analysis on DPDMCs Storage Facilities

- **Holistic Approach**

- In order to make full use of the merits derived from DPDMCs, it is desirable that primary lids of DPDMCs not opened in storage facilities (Storage facilities do not equip with hot cells.)
- Holistic approach needed as one typical operational cycle for DPDMCs are longer than storage period, and interrelates both to storage and transport.

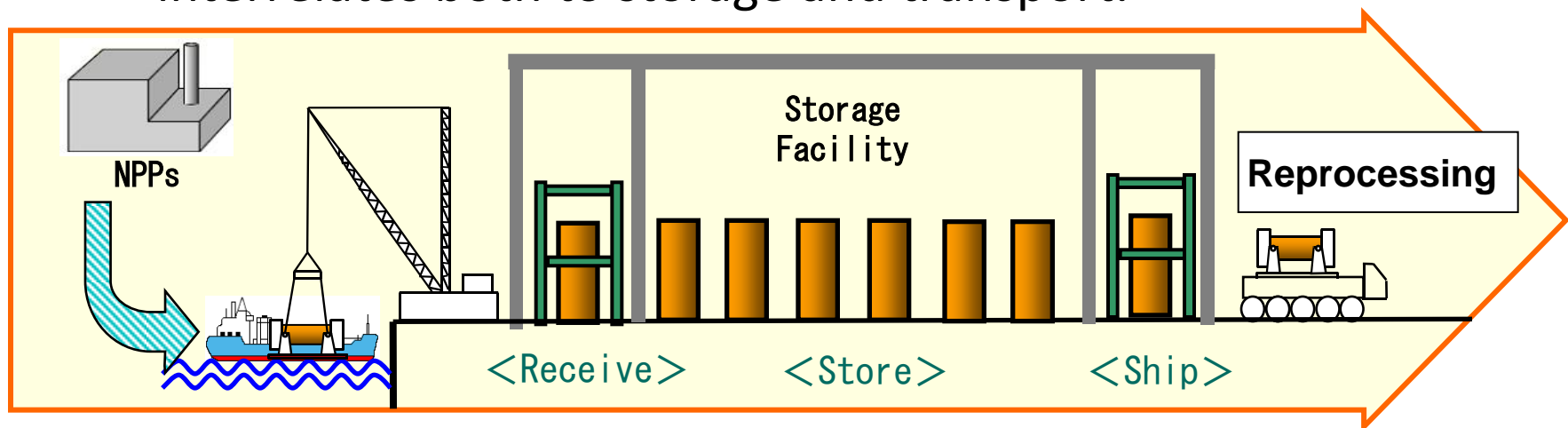

Interface Issues Concerning Dual Purpose Dry Metal Cask Storage

▶ Holistic Approach ~ Safety Issues

< Interface Issue No.1 >

Post storage transport safety depends on safety during storage.

- In making safety analysis for the transport license of DPDMCs, transport regulatory authority should well take into consideration of possible long-term deterioration of cask materials as well as spent fuels inside the casks.
- It is advisable that necessary analysis of such deterioration should be conducted in accordance with storage's safety analysis.

Interface Issues Concerning Dual Purpose Dry Metal Cask Storage

▶ Interface Issue 3

- Storage safety significantly dependent on the “transportability” of casks during storage.
 - In case of confinement mechanisms failure (i.e., deterioration of metal gaskets in the primary lid), casks have to be transported to sites where they can be fixed.
 - It is important that these casks are designed in such a manner that they can safely be transported to these sites even in cases when their containment mechanisms failed.
 - Equipping additional tertiary lid for casks can be one example to meet such requirements.

Interface Issues Concerning Dual Purpose Dry Metal Cask Storage

▶ Interface Issue 4

- Post storage transport safety significantly dependent on documentation (records) during storage.
 - SFs stored in these casks, even after storage of decades, are not expected to experience any significant deterioration that would affect post storage transport or their acceptability in their destinations.
 - Inspections securing safety of post storage transport are to be conducted based on documentations (records) during storage.
 - It is important to identify which data during storage can be used to verify which requirement for transport.

Holistic Approach in Regulatory Process adopted to meet Interface Issues

▶ Item 1

- Licensing procedures of storage and transport are to be conducted in line with safety analysis of storage facilities.
 - Safety analysis of storage and transport are to be conducted in a harmonious way.
 - Transport license of each storage cask is required to maintain validity during storage.

Holistic Approach in Regulatory Process adopted to meet Interface Issues

▶ Item 2

- Licensing procedures of storage require clear identification of the role of related operators.
 - Storage operators are requested to clearly identify the role of the owner of SFs.
 - Regularly, the role of the owners of SFs includes loading operation and transport of casks.

Holistic Approach in Regulatory Process adopted to meet Interface Issues

▶ Item 3

- Those who are responsible for transport of casks are required to sufficiently demonstrate that transport after storage can safely be conducted.
 - It is required to demonstrate that deterioration of SFs rods during storage will not affect post-storage transport safety in any conditions including accident conditions.
 - In addition, it is required to demonstrate that integrity of SFs at the end of storage is maintained within designed safety margins based on inspection data obtained during storage.

Thank you for your attention!

Shuhei KOJIMA

Director, Nuclear Fuel Transport and Storage Regulation Division
Nuclear and Industrial Safety Agency(NISA)

kojima-shuhei@meti.go.jp
